

QuickPlate Instructions

The Haweka Quick Plate is a fast, intuitive, easy to use variable adaptor plate that has been certified by TUV Nord and is subject to strict quality control throughout the manufacturing process. It is available in 4, 5 and 6 lug plates covering pitch circle diameters from 94 to 188mm. Quick plates are easily adjusted to fit any passenger car, light truck and SUV bolt hole pattern past, present and future. The revolutionary user friendly design allows shops to get premium balancing results on every wheel without sacrificing valuable bay time.

Haweke Quick Plates function to mimic the wheel's lug nuts by providing even pressure from the front of the wheel to control side to side movement, or dynamic imbalance, on the balancer. Used in combination with a hub centering unit (cone, collet, duo collet) and quick nut/wing nut, Quick Plates enable wheels to be mounted on the balancer exactly as they are on the vehicle. Additionally, Quick Plates make no contact with the wheel's surface preventing damage and scratching to any finish or cover on wheels.

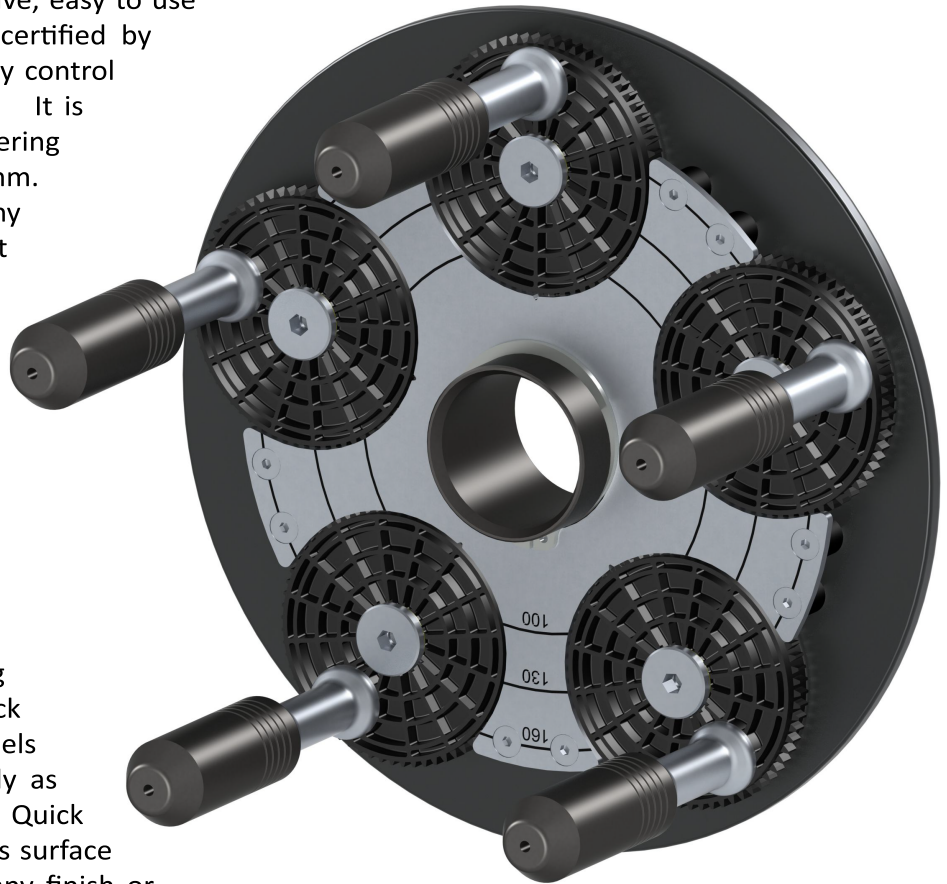

Pre - Instructions

1. Quick Plates used in any other manner than as front loaded pressure plate in conjunction with a back loaded hub centering unit and quick nut/wing nut is not intended.
2. Any changes made to the construction of the Quick Plate will elicit inaccurate results and void warranty.
3. Quick Plates must only be used on wheel balancers that conform to applicable safety regulations.
4. Quick Plates are part of a precision measuring system and must always be used, handled and stored with utmost care.
5. Improper use, handling and storage of Quick Plates and any damage to the product or personal injury resulting from inappropriate use, handling and storage is not the responsibility of the manufacturer, Haweka or Allpart.

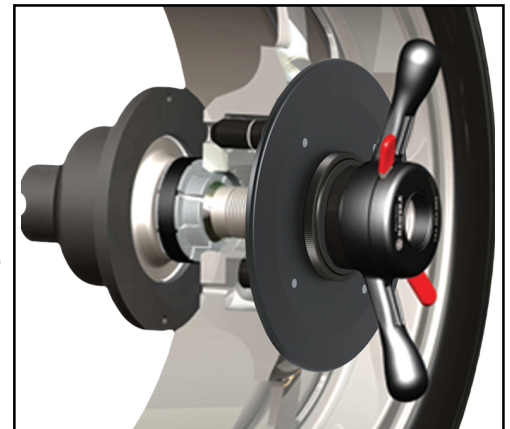

QuickPlate Instructions

Quick Plate Tip Instructions

TIP SELECTION

Selecting the correct Quick Plate Tip for the wheel to be balanced is essential to the perfect centering of the rim on the balancer. Tips should always have an exact fit in the bolt hole of the rim. Different tips are required for different rim designs. Haweka Quick Plate Tips are color coded by rim type.

BASE STUD INFO

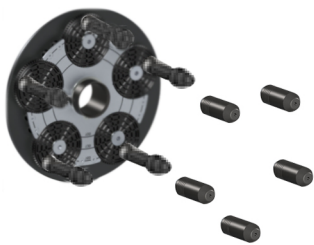

The base studs are fixed to the QuickPlate. Only the stud tips need to be exchanged for different lengths and lug nut types.

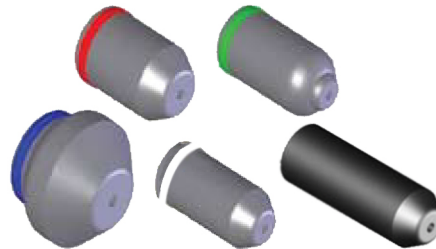
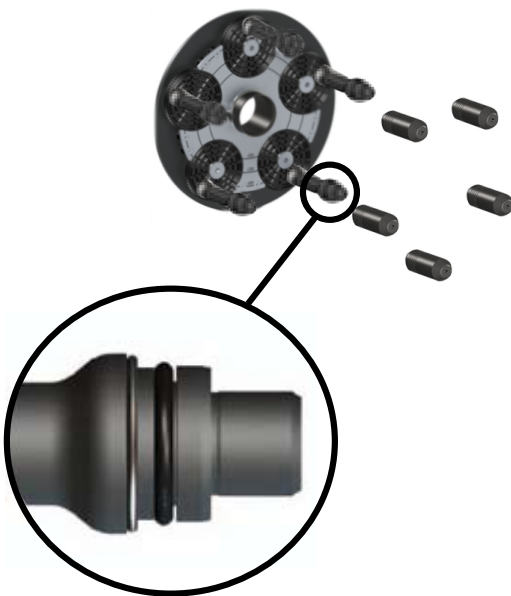
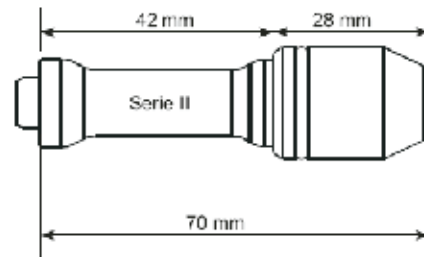

QuickPlate Instructions

Application Guide for QuickPlate Tips













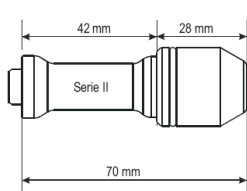

ATTENTION

1. Never use different tips at the same time on the Quick Plate. The type must be uniform on all Quick Plate studs.
2. Never use the Quick Plate with out populating each stud with the correct tip. The absence of any one tip on the Quick Plate will invalidate balancing results.

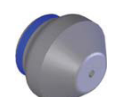
INSTALLING AND REMOVING TIPS

Installing and removing Quick Plate Tips is fast and easy. Here are the steps:

1. Before fixing the tip on the stud, make sure that the o-ring and supporting spring are present on the stud (see picture to right) and in the right position.
2. For installation, select the right tip for the wheel application then press it on to the stud, twisting slightly until engaged.
3. Always make sure the tip is secure and in the correct position prior to use.
4. For removal, slightly twist and pull the tip from the stud.
5. Quick Plate Tips must always be stored properly and immediately after use.

Base Stud Info	Picture & Part #	Total Installed Length	Application Example	Lug Nut Examples
 <p>The base studs are fixed to the QuickPlate. Only the stud tips need to be exchanged for different lengths and lug nut types.</p>  	 273e008 003	3.15" (80 mm)	Can be used on all steel wheels and most aluminum wheels with a standard straight taper Required for Toyota Truck/SUV application using collet HW160 400 062	
	 273e008 007	3.5" (90 mm)	Use for all vehicles with a spherical style lug nut Use on vehicles with shank lug nuts	 
	 273e008 008	2.75" (70 mm)	Use on select Land Rover vehicles with the large lug nut	
	 273e008 025	3.95" (100 mm)	Can be used on all steel wheels and most aluminum wheels with a standard straight taper (Found mostly on Suv's)	
	 273e008 023	3.95" (100 mm)	Use on Tuner wheels and virtually all aftermarket custom wheels	

QuickPlate Instructions

Quick Plate Use Instructions

Finding the PCD (Pitch Circle Diameter)

1. Lay the first wheel flat on the ground.
2. Position the Quick Plate with the correct tips for the wheel in to the bolt holes.
3. Maneuver the studs, using the thumb dials around the Quick Plate, until they are situated exactly in the rim's bolt holes. You have now established the PCD.
4. To fix the PCD, turn the break ring on the back of the Quick Plate to right to lock the stud movement.
5. Do not forcefully turn or tighten heavily. Turn the break ring just enough to hold the PCD in place.
6. The PCD must always be fixed so that it is not lost when transferring the wheel to the balancer.
7. Once the PCD is fixed, it can be used on all four wheels without having to repeat the process.



Quick Plate Storage

It is vitally important to make sure Quick Plates and Quick Plate Tips are stored properly after each use. Allpart and Haweka have developed the following options for Quick Plate storage:

Quick Plate Wallboard

HW900 008 151 (included in Quick Plate kit HW200 456 xx9)
The wallboard can be fixed to any shop wall or to a storage stand (see below). It is recommended that it be located close to the balancer.



Storage Stand (Works with Wallboard)

HW900e008 190

Allpart Adaptor Tree

HW900 008 500

