

Challenger Lifts

INNOVATIVE LIFTING SOLUTIONS



Model#: EW0820S090

Wide Inground Lift
8,000 lb. lifting capacity

**Engineered for Wide Body
and Electric Vehicles!**

8,000lb Wide Inground

Challenger Lifts' EW0820 Wide-electric hydraulic cassette-style inground EnviroLift® meets the rigorous demands of professional service facilities. With enhanced wipers, both top and bottom, and 5" chrome pistons, your shop will have a superior, more stable and repeatable lift resulting in increased productivity. These inground lifts also eliminate environmental concerns with a fully contained galvanized steel cassette tub.

It features chrome pistons, extra wide drive-through 3-Stage Arms and double telescoping screw pads. Packaged with Bench Mounted Controls (BMC)



Features & Benefits

- Chrome non-breathing ram style cylinder minimizes water intake and other contamination
- Enhanced wiper at top and bottom of bearing provides better grease retention and minimizes contaminants from entering into bearings
- Mechanical lock engages every 3" provides safety and allows technician to work at their ergonomic height to increase productivity and minimize fatigue
- Fully contained and sealed galvanized steel cassette tub eliminates risk of hydraulic fluid seeping into the ground
- Double telescoping screw adjusts from 3.75" to 5.75" with removable rubber pad for frame contact
- Wide drive-thru at 102" accommodates wider vehicles, minimizes tire pinching and provides easy drive-on

Model Number	EW0820
Lifting Capacity	8,000 lb. (3628kg)
A Rise Height	73.25" (1861mm)
B Width Overall	115.75" (2940mm)
C Drive-Thru Clearance	102" (2591mm)
D Arm Reach Min	25.25" (641mm)
E Arm Reach Max	45.25" (1149mm)
F Min. Screw Pad Height	3.75" (95mm)
Capacity (Per Arm)	2,000 lb.
Guide Plunger Diameter	
Motor	3HP
Voltage (Single Phase Std.) ²	208v - 230v
Speed of Rise	38 Seconds
Air Required	75 - 125 psi

Challenger Lifts
INNOVATIVE LIFTING SOLUTIONS
challengerylfts.com

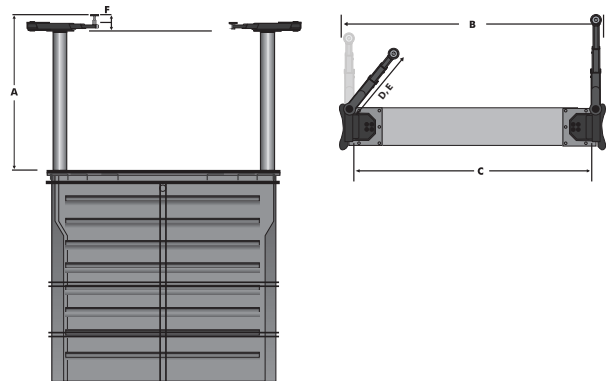

**IDEAL FOR ELECTRIC AND WIDE VEHICLES,
 WHEN COMPLETE ACCESS TO UNDERCARRIAGE IS NECESSARY FOR BATTERY OR OTHER SERVICING.**

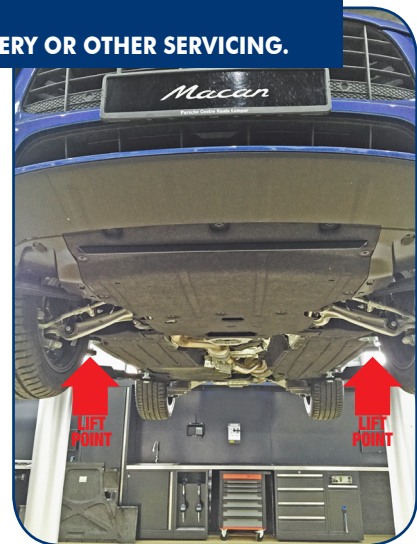
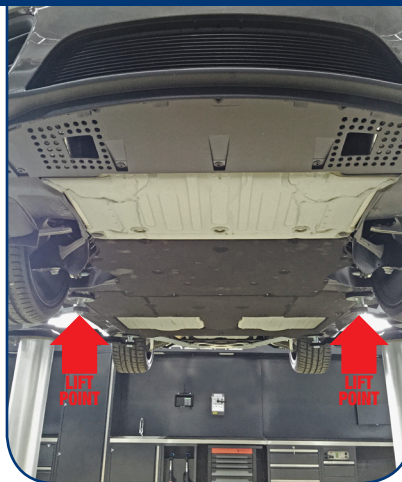
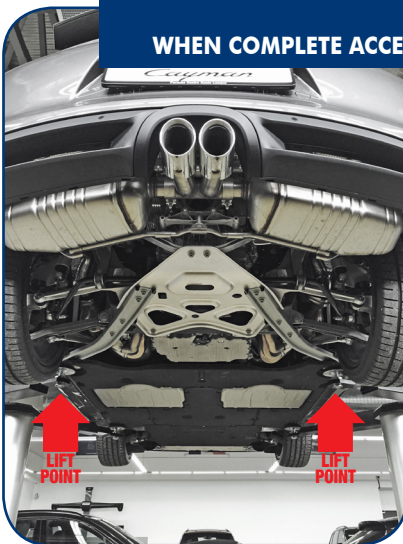

For more information, contact your Authorized Challenger Lifts Distributor:

AAIA
 Automotive Aftermarket
 Industry Association



CHALLENGER LIFTS, INC.
 2311 South Park Rd.
 Louisville, Kentucky 40219

Phone Toll-Free: 800-648-5438
 502-625-0700
 Fax: 502-625-0711
 E-mail: sales@challengerylfts.com

Challenger Lifts, Inc. reserves the right to make changes to specifications without notice and without making changes retroactive. Unloading, installation and oil not included.