

ADG

AUTOMOTIVE

SERVICE EQUIPMENT

EXCELLENCE
BY DESIGN

Model M-RAPTOR

Ultra High Performance Lever-Less Tire Changer

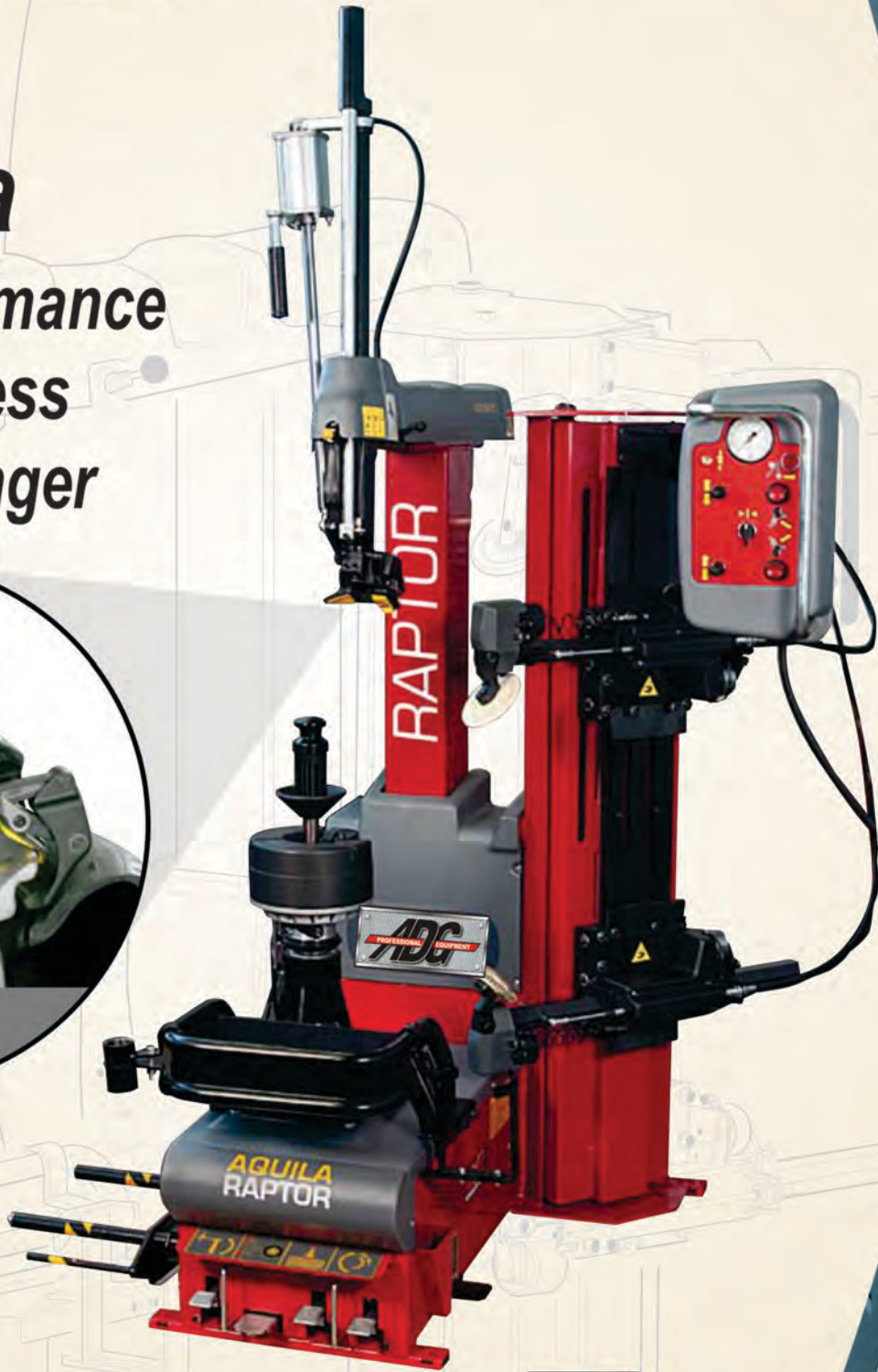
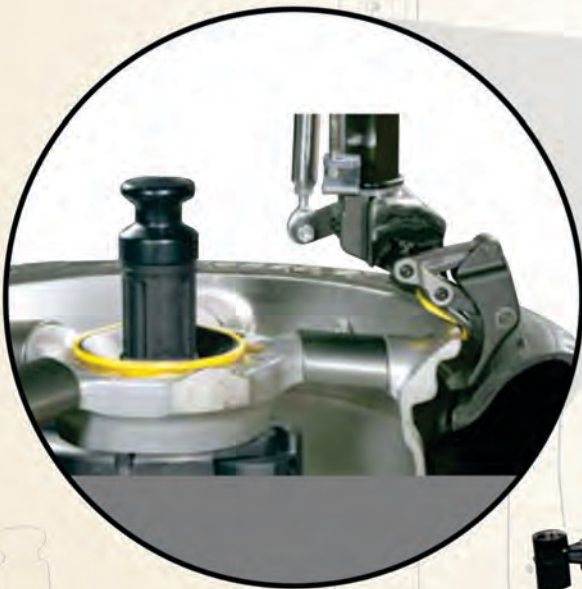

Professional Wheel Service equipment manufactured by



Distributed and Supported Exclusively by the members of The Automotive Distributions Group, Inc.

www.ADGEquipment.com | 800-497-0009

Superior Engineered Performance To Change Today's Most Demanding Tire/Wheel Configurations



The pedal positioning is designed so the technician can easily control the wheel lift while safely guiding the tire into position



Ergonomically designed wheel lift provides pneumatic power for raising & positioning tire/wheel assemblies of up to 185 lbs with virtually no risk of technician back strain.



Right side mounted adjustable control panel is designed for fast, easy intuitive operation of all machine functions.



Coordinated top and bottom rollers offer multi-function versatility Clamping Tire, Positioning Tire/Rim assembly, Breaking Beads, all controlled from an ergonomically located control panel.

Designed to handle the most demanding tire and wheel configurations available as Original Equipment or High Performance Aftermarket.



Advanced engineering research has created the optimal roller shape & ideal angle of penetration. Technician can change the bead depressing wheel angle of approach to either 35 degrees or 50 degrees dependent on the contour and composition of the rim, providing maximum tire changing versatility



The traditional Mount/Demount head has been completely redesigned eliminating the need for the 'tire pry bar' and subsequently eliminating the risk of damage to the tire by forcing. This amazing design eliminates the need for excessive physical effort by the technician.

Standard accessories



Optional accessories

8-11100156
Reverse Wheel
flange kit



8-11100046 Extension
Kit for the 8-11100156
Flange kit.



8-11100128
Pressmate
Optional left side
mounted pneumatic
bead depressor and
following arm

Technical Specifications

	RAPTOR
Wheel Diameter	12" - 28"
Max Tire Diameter	42"
Max Wheel Width	15"
Turntable Rotation Torque	880 Ft/lbs
Clamp Rotation	6 - 15 RPM
Force Applied By Bead Breaker	1236 Lb/F
Wheel Lifter Load Capacity	185 lbs
Working Pressure	145 lbs
Electrical Requirements	2 Speed Motor 220V 60Hz Single Ph
Weight	1050 lbs

Dimensions

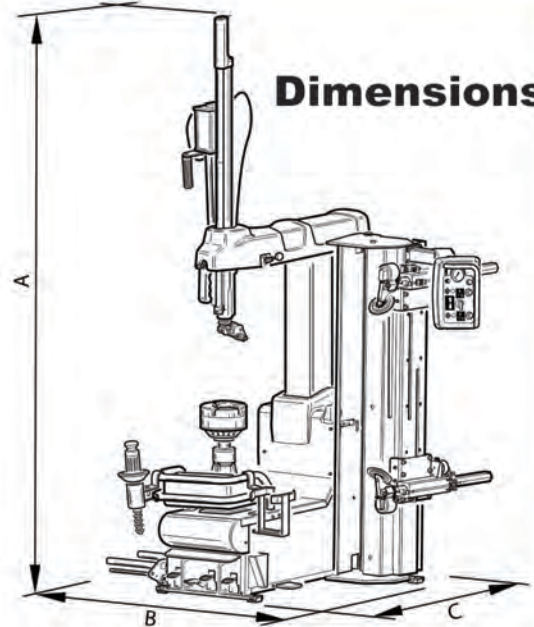

	min	max
A	47.25"	67.25"
B	36.25"	78.75"
C	48"	69.5"



Distributed by