

# CL Challenger Lifts



**Model#: CLFP9**

Floor Plate 2-Post Lift  
9,000 lb. capacity

## CLFP9



**CLFP9:**  
3-stage front + 3-stage  
rear arms

The CLFP9 features a 10' 7/8" overall column height, making it ideal for low ceiling applications. Standard front and rear 3-stage arms provide maximum arm sweep, arm retraction and reach. CLFP9 will accommodate a wide variety of vehicle lifting points, including short and long wheelbase and wide body imports.

Other features include double telescoping screw pads, durable powder coat finish, plated arm pins, and a Heavy-Duty chain and hydraulic lifting system with cable synchronization, just to name a few. Available in red and blue.

## Features & Benefits:

- 10' 7/8" overall column height is ideal for servicing vehicles in a low ceiling height
- Low profile drive-over floor plate for easy vehicle positioning
- 3-stage front + 3-stage rear arms provide excellent reach and retraction to lift a variety of vehicles
- Electric/hydraulic heavy-duty chain lifting operation with cable equalization
- Dual point mechanical pull-lock cable release system
- Fully gusseted base plate design reduces column deflection
- Double telescoping screw pads adjust to multiple heights minimizing the need for adapters
- Rubber foot pads minimize stress to vehicle's delicate undercoatings
- Premium powder coat finish provides long-lasting durability
- Plated Arm Pins inhibit rust and provide long-lasting durability
- Many accessories available to turn CLFP9 into a complete productivity center.



The CLFP9 features a Heavy-Duty chain lifting system with cable equalization.

For more information, contact your Authorized Challenger Lifts Distributor:



CLFP9	Specifications
Lifting Capacity*	9,000 lb. (4082kg)
<b>A</b> Rise Height <sup>1</sup>	79 1/8" (1984mm)
<b>B</b> Column Height	10' 7/8" (3070mm)
<b>C</b> Overall Width	11' 5 1/2" (3493mm)
<b>D</b> Drive-thru Clearance	98 3/16" (2494mm)
<b>E</b> Front Arm Reach	24 1/2" - 44 1/2" (623 - 1131mm)
<b>F</b> Rear Arm Reach	24 1/2" - 44 1/2" (623 - 1131mm)
<b>G</b> Screw Pad Height <sup>2</sup>	Adj. 4 1/4" - 6 1/2" (102mm - 149mm)
<b>H</b> Inside of Columns	109" (2769mm)
Ceiling Height Required	121 7/8" (3096mm)
Motor	2HP, Single Phase, 60Hz
Voltage	208 - 230v
Speed of Rise	60 seconds
Max. Load Per Arm	2,250 lb. (1020kg)

\*Lift capacity ratings are based on loads equally distributed on all four arms.

<sup>1</sup> Rise height measured with telescoping screw pad in highest position

<sup>2</sup> Specifications are listed without rubber pad, for measurements with rubber pad add 1/4" (6mm).

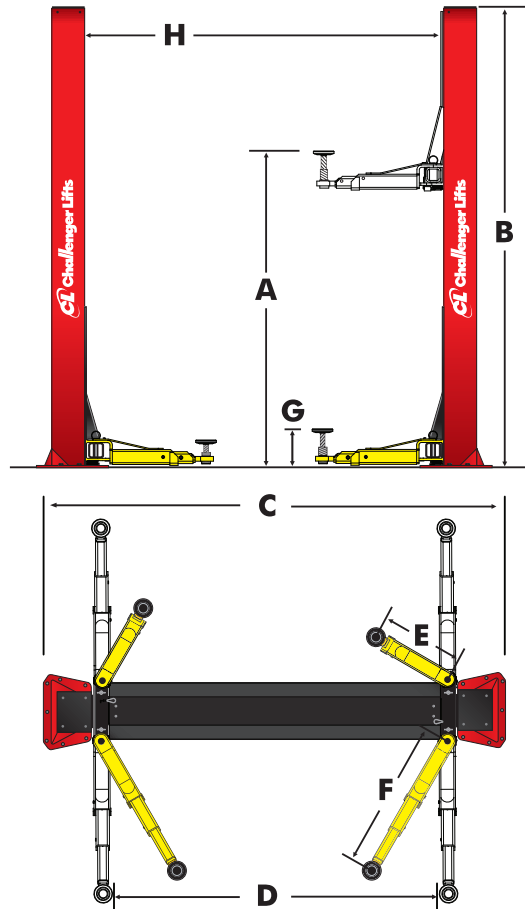

**AAIA**  
Automotive Aftermarket  
Industry Association

CHALLENGER LIFTS, INC.  
200 Cabel Street  
Louisville, Kentucky 40206

Phone Toll-Free: 800-648-5438  
502-625-0700  
Fax: 502-625-0711  
E-mail: sales@challengelifts.com

Challenger Lifts, Inc. reserves the right to make changes to specifications without notice and without making changes retroactive. Unloading, installation and oil not included.